

SPIRIT 122 PSU

SPIRIT122
SKY LINE
MWFLY PSU

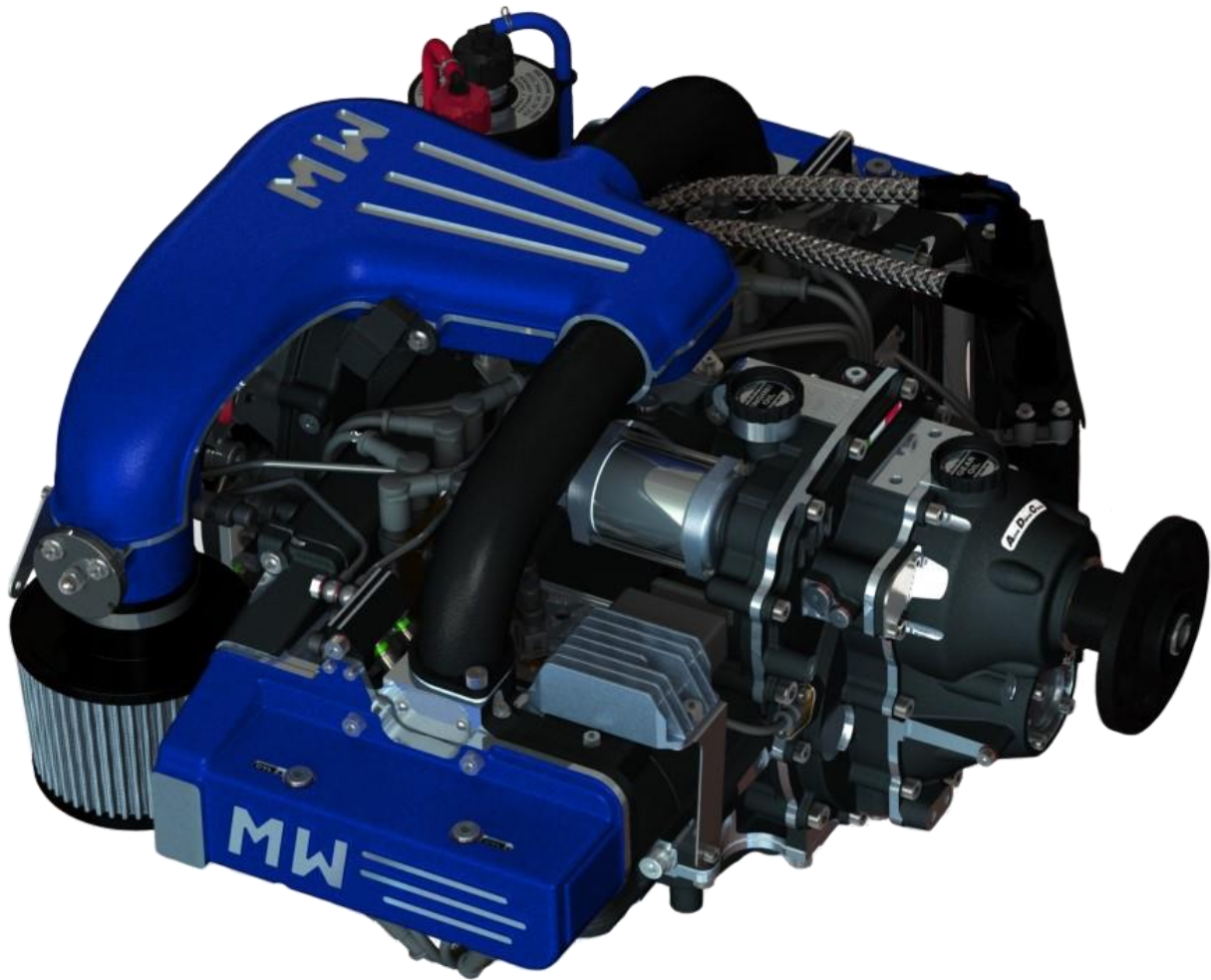

Applicability

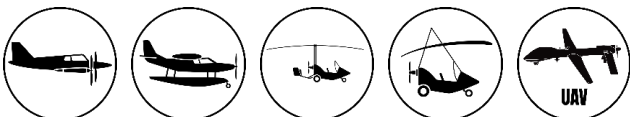



DATA SHEET SPIRIT 122Hp PSRU

Document
E-DTD.W015.001

Edition
A

Revision
1

Engine data

Model/Code	Spirit 122 PSRU / W015 (left rotation) – W016 (right rotation)
Type	4 cylinder boxer - 4 Stroke fuel (Otto cycle)
Displacement [cm ³ (in ³)]	2201 (134)
Weight [Kg (lb)]	86,5 (190,7) dry
Dimension L x W x H [mm (in)]	673 x 749 x 419 (26,5 x 29,49 x 16,5)
Stroke X Bore [mm (in)]	81 x 93 (3,18 x 3,66)
Compression Rate	10,3 ÷ 1
Fuel	Mo.GAS min. AKI 90, R.O.N. 95, M.O.N. 85, LL100
Cooling System	Liquid with mechanical pump
Lubrication	Semi-dry sump, pressure oil feed assisted with internal pump
Timing System	2 valves per cylinder with S.O.H.C. (Single Over Head Camshaft)
Timing Driving System	Gear + chain with automatic chain tensioner
Pre-installed Accessories (included in the weight)	Engine wiring loom, voltage regulator, start relay, dampers, ignition coils, cooling expansion tank

Transmission



Type	Gearbox with helical gear (separate lubrication)
Transmission Ratio	1 ÷ 1,732
Max Propeller Speed [rpm]	2450
Damper	Elasto-dissipative with Active Damping Control (A.D.C)
Optional	Integrated constant speed hydraulic governor

Electric data

Generator	Permanent magnet, oil cooled, 260W (12,5V-21A)
Optional Generator	750W (12,5V-60A); 2250W (12,5V-90A); 2250W (25V-180A)
Starter	Electric 0,65kW with anti-kickback clutch
F.R.I.S. (Full Redundancy Injector System)	ECU with dual injection and ignition; altitude and temperature compensation; Limp home strategy
CAN Data Transmission	CAN Aerospace protocol

Performance

Max Power [kW (Hp)]	89,7 (122) @ 4200 rpm
Max Torque [Nm (lb-ft)]	213 (157,1) @ 3100 rpm
Max Continuous Power [kW (Hp)]	80,9 (110)
Max Engine Speed [rpm]	4250
Power/Weight [Hp/Kg (Hp/lb)]	1,41 (0,64)
Fuel Cons. [Kg/h (lb/h)]	12,6 (27,7) @ 75 Hp
TBO [h]	2000

DIMENSIONS

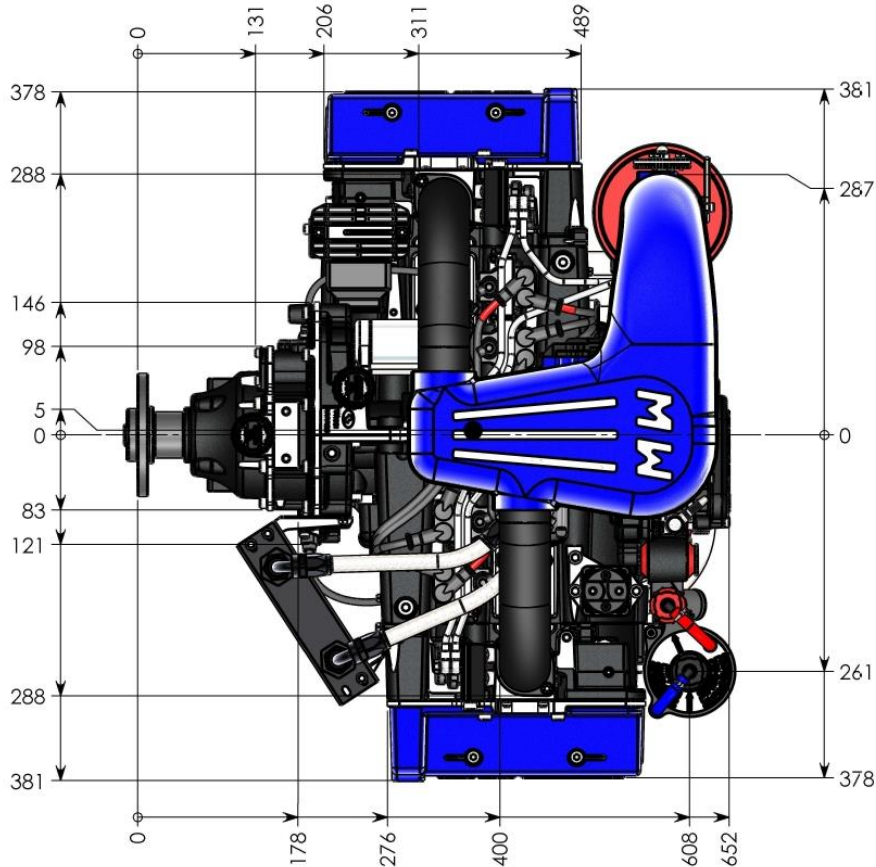
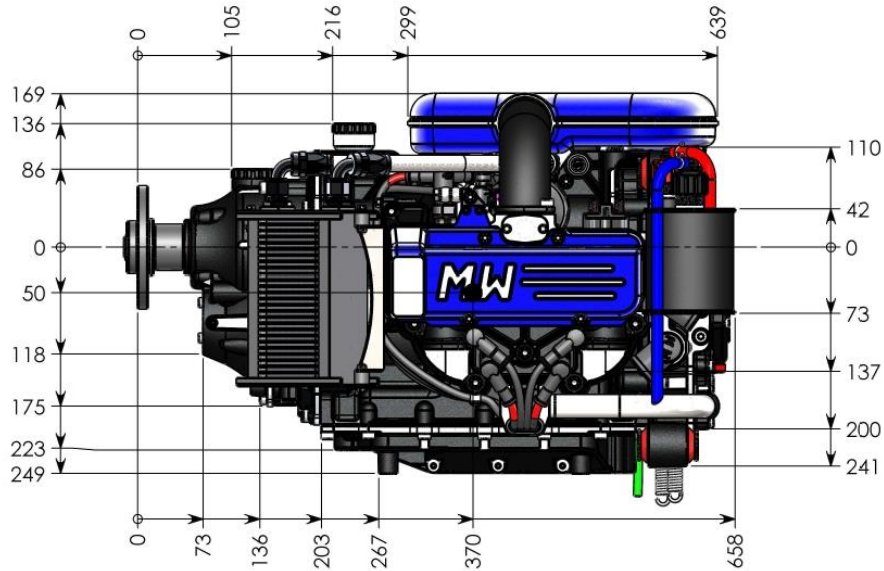

ATTACHMENT POINTS

