



**DATA SHEET
SPIRIT 210Hp
PSRU**

Document
E-DTD.W029.001

Edition
A

Revision
1

SPIRIT 210 TURBO PSRU



Applicability



TRANSLATED

FREE DISCLOSURE



DATA SHEET SPIRIT 210Hp PSRU

Document
E-DTD.W029.001



Edition
A

Revision
1

Engine data

Model/Code	Spirit 210 Turbo PSRU / W029 (left rotation) - W030 (right rotation)
Type	4 cylinder boxer - 4 Stroke fuel (Otto cycle)
Displacement [cm3 (in3)]	2545 (155)
Weight [Kg (lb)]	101 (222,6) dry
Dimension L x W x H [mm (in)]	705 x 749 x 600 (27,76 x 29,49 x 23,62)
Stroke X Bore [mm (in)]	81 x 100 (3,18 x 3,93)
Compression Rate	8,5 ÷ 1
Critical Altitude [ft]	16000
Max Overpressure Ratio	1,6
Fuel	Mo.GAS min. AKI 90, R.O.N. 95, M.O.N. 85, LL100
Cooling System	Liquid with mechanical pump
Lubrication	Semi-dry sump, pressure oil feed assisted with internal pump
Timing System	2 valves per cylinder with S.O.H.C. (Single Over Head Camshaft)
Timing Driving System	Gear + chain with automatic chain tensioner
Pre-installed Accessories (included in the weight)	Engine wiring loom, voltage regulator, start relay, dampers, ignition coils, cooling expansion tank, intercooler with hoses

Transmission

 	
Type	Gearbox with helical gear (separate lubrication)
Transmission ratio	1 ÷ 1,732
Max Propeller Speed [rpm]	2450
Damper	Elasto-dissipative with Active Damping Control (A.D.C)
Optional	Integrated constant speed hydraulic governor

Electric data

Generator	Permanent magnet, oil cooled, 260W (12,5V-21A)
Optional Generator	750W (12,5V-60A); 2250W (12,5V-90A); 2250W (25V-180A)
Starter	Electric starter 0,65kW with anti-kickback clutch
F.R.I.S. (Full Redundancy Injector System)	ECU with dual injection and ignition; altitude and temperature compensation; Limp Home strategy
CAN Data Transmission	CAN Aerospace protocol

Performance

TRANSLATED

FREE DISCLOSURE

Page 2 of 8



**DATA SHEET
SPIRIT 210Hp
PSRU**

Document
E-DTD.W029.001

Edition A	Revision 1
---------------------	----------------------

Max Power [kW (Hp)]	156,6 (210) @ 4200 rpm
Max Torque [Nm (lb-ft)]	351 (258,9) @ 4200 rpm
Max Continuous Power [kW (Hp)]	126,8 (170)
Max Engine Speed [rpm]	4250
Power/Weight [Hp/Kg (Hp/lb)]	2,08 (0,93)
Fuel Cons. [Kg/h (lb/h)]	14,5 (31,9) @ 75Hp
TBO [h]	1800



DATA SHEET SPIRIT 210Hp PSRU

Document
E-DTD.W029.001

Edition
A

Revision
1

DIMENSIONS

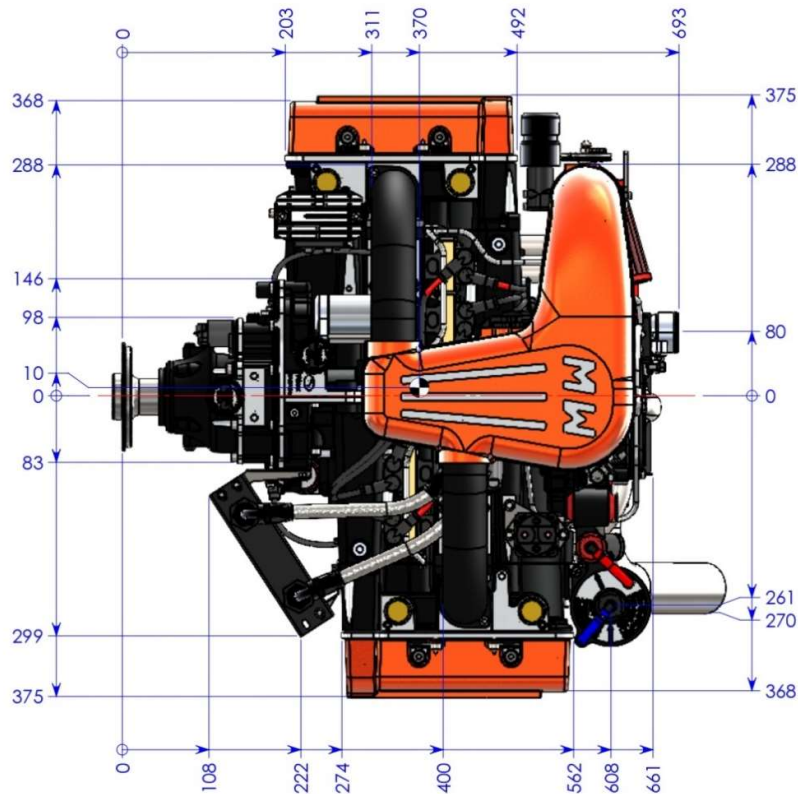
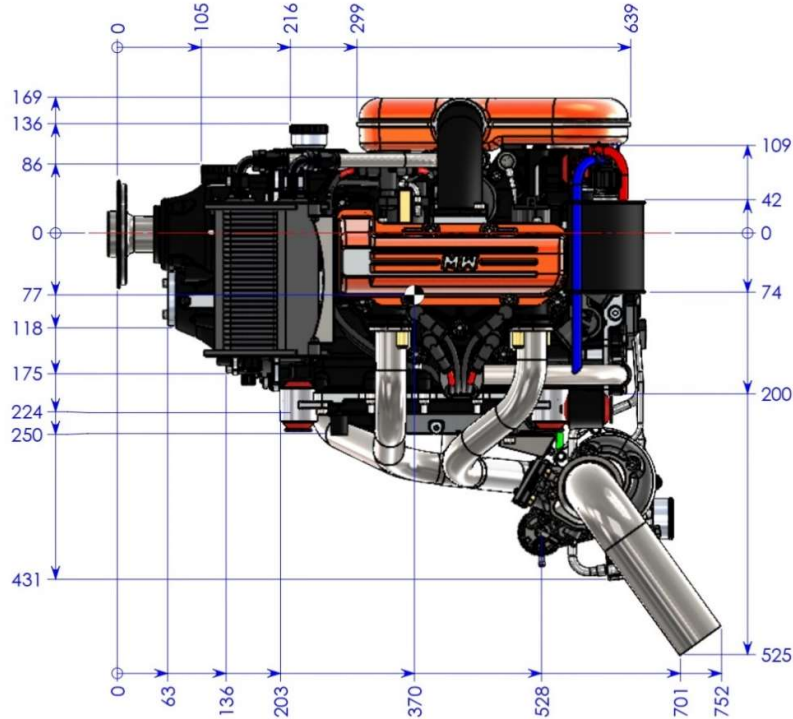

ATTACHMENT POINTS

